



<b>MARIANO MARCOS STATE UNIVERSITY</b> Procurement Division	Document Code	PD-FRM-002	
	<b>Request for Quotation (RFQ)</b> <b>(Goods and Services)</b>	Revision No.	4
Effectivity Date		January 8, 2021	

**REQUEST FOR QUOTATION (RFQ)**

Date: 11/4/21  
PR No. 2021-11-300 (0110101)

Sir/Madam:

Please quote your lowest price on the item/s listed below, and submit your quotation duly signed by you or your duly authorized representative not later than **3 days** subject to the Terms and Conditions provided at the last page of this RFQ.

Delivery period must be at least within **10 days** upon receipt of the Notice to Proceed or Purchase Order.

For any clarification, you may email us at [bac@mmsu.edu.ph](mailto:bac@mmsu.edu.ph).

*NATHANIEL R. ALIBUYOG*  
BAC Chair

ITEM	QTY	Unit	ITEM DESCRIPTION	ABC/unit	UNIT PRICE
1	100	pcs	<b>Acrylic Mobile Partition</b> 3mm. Thk. Acrylic sheet on powder coated white aluminum frame with rollers (See attached drawing as reference)  Note: This includes supply, fabrication, and delivery of the acrylic mobile partitions	6,500.00	

**TOTAL ESTIMATED BUDGET: 650,000.00**

REMARKS/NOTE: \_\_\_\_\_  
 \_\_\_\_\_  
 \_\_\_\_\_

After having carefully read and accepted your Terms and Conditions, I/we submit our quotation/s on the item/s at prices indicated above.

Business Name: \_\_\_\_\_  
 Business Address: \_\_\_\_\_  
 Printed Name of the Owner: \_\_\_\_\_  
 TIN: \_\_\_\_\_  
 PhilGEPS Registration Number: \_\_\_\_\_  
 Business Permit: \_\_\_\_\_  
 Omnibus Sworn Statement: \_\_\_\_\_  
 Annual Income Tax Return: \_\_\_\_\_

\_\_\_\_\_  
 Signature over Printed Name  
 \_\_\_\_\_  
 Tel. No./Cellphone No./e-mail address  
 \_\_\_\_\_  
 Date

Canvassed by: \_\_\_\_\_

*Disclaimer: Reproduction of this form is allowed subject to compliance to the Documented Information Procedure established by MMSU.*



<b>MARIANO MARCOS STATE UNIVERSITY</b> <b>Procurement Division</b>	Document Code	PD-FRM-002	
	Revision No.	4	Page 2 of 2
	Effectivity Date	January 8, 2021	

**Request for Quotation (RFQ)**  
**(Goods and Services)**

**TERMS AND CONDITIONS:**

1. Bidders shall provide correct and accurate information required in this form.
2. Bidders may quote for any or all of the items.
3. Bidders shall submit a copy of the following documents along with the Quotation:
  - a. Mayor's/Business Permit
  - b. Notarized Omnibus Sworn Statement (if ABC is more than P 50,000.00)
  - c. Income/Business Tax Return (if ABC is more than P 500,000.00)
4. Price quotation/s, to be denominated in Philippine peso, shall include all taxes, duties and/or levies payable.
5. Quotations exceeding the Approved Budget for the Contract shall be rejected.
6. Award of contract shall be made to the lowest quotation which complies with the minimum technical specifications and other terms and conditions stated herein.
7. Any interlineations, erasures or overwriting shall be valid only if they are signed or initialed by you or any of your duly authorized representative/s.
8. The item/s shall be delivered according to the requirements specified in the Technical Specifications.
9. The University has the right to inspect and/or test the goods to confirm their conformity to the technical specifications.
10. Liquidated damages equivalent to one tenth of one percent (0.1%) of the value of the goods not delivered within the prescribed delivery period shall be imposed per day of delay.

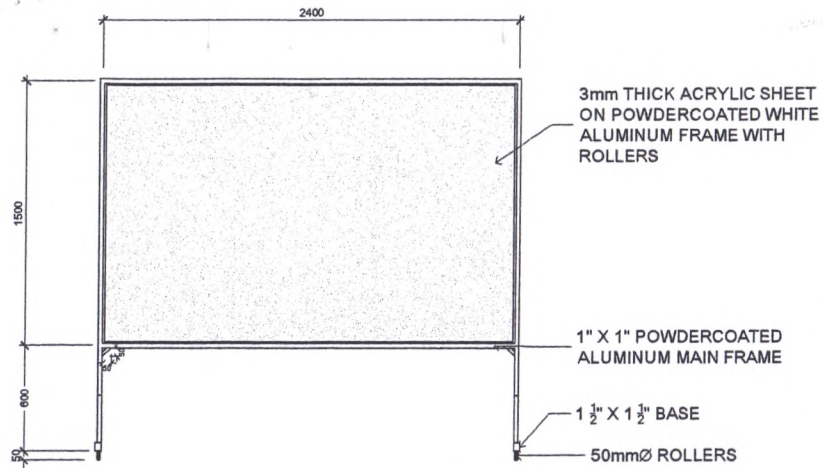

FRONT ELEVATION

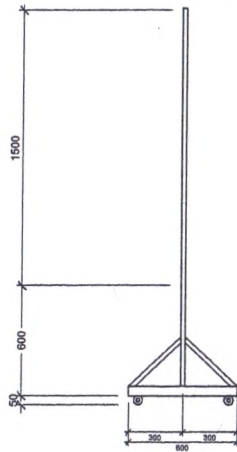

SIDE ELEVATION

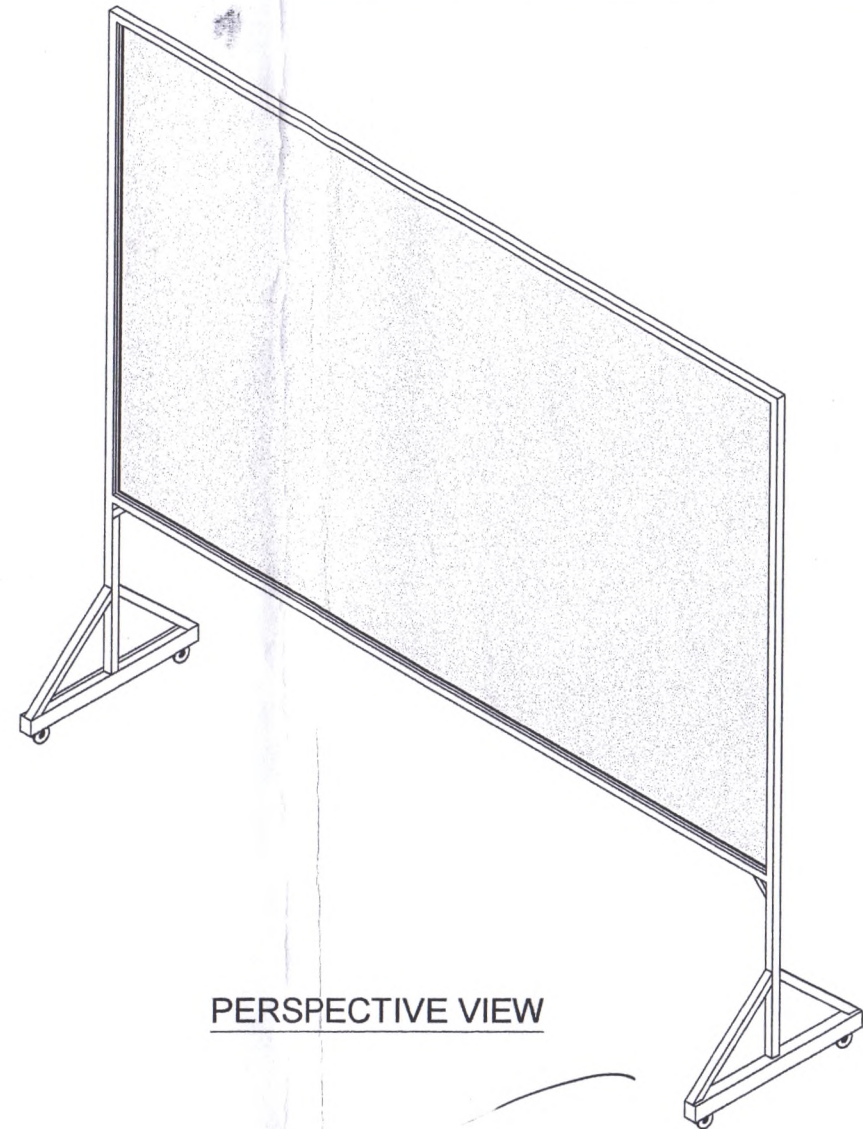

PERSPECTIVE VIEW



3D/ DRAWN BY:  
*[Signature]*  
**ANNE LOIZE VALERIE EDUARTE**  
DRAFTSMAN  
 PREPARED BY:

PROJECT TITLE:  
**ACRYLIC MOBILE PARTITION**  
 PROJECT LOCATION: MARIANO MARCOS STATE UNIVERSITY

CHECKED/ REVIEWED BY:  
*[Signature]*  
**AIDA V. CABANG**  
ARCHITECT IV, CHIEF, PHYSICAL PLANNING SECTION  
 CONFORME:  
*[Signature]*  
**PRIMA FE R. FRANCO**  
VP FOR ACADEMIC AFFAIRS

RECOMMENDING APPROVAL:  
*[Signature]*  
**ROMEO R. DALDULAO**  
ENGINEER IV, DIRECTOR, PPDO  
 APPROVED BY:  
*[Signature]*  
**SHIRLEY D. AGRUPIS**  
UNIVERSITY PRESIDENT

SHEET CONTENT:  
**AS SHOWN**

SHEET NO: